



**Superlift Steering Stabilizer for 2007 and Newer
Jeep Wrangler (JK) 4WD and 2WD
INSTALLATION INSTRUCTIONS**

INTRODUCTION

Installation requires a professional mechanic. Prior to beginning, inspect the vehicles steering, driveline, and brake systems, paying close attention to the suspension link arms and bushings, anti-sway bars and bushings, tie rod ends, pitman arm, ball joints and wheel bearings. Also check the steering sector-to-frame and all suspension-to-frame attaching points for stress cracks. The overall vehicle must be in excellent working condition; repair or replace all worn parts.

Read instructions several times before starting. Be sure you have all needed parts and know where they install. Read each step completely as you go.

NOTES:

- **Prior to beginning the installation, check all parts and hardware in the box with the parts list below. If you find a packaging error, contact Superlift directly. Do not contact the dealer where the system was originally purchased. You will need the control number from each box when calling; this number is located at the bottom of the part number label and to the right of the bar code.**
- An arrow on diagrams indicates which direction is toward the front of the vehicle.
- A foot-pound torque reading is given in parenthesis () after each appropriate fastener.
- After drilling, file smooth any burrs and sharp edges.
- Paint or undercoat all exposed metal surfaces.
- Prior to attaching components, be sure all mating surfaces are free of grit, grease, undercoating, etc.
- A factory service manual should be on hand for reference.
- Use the check-off box “” found at each step to help you keep your place. Two “ ” denotes that one check-off box is for the driver side and one is for the passenger side. Unless otherwise noted, always start with the driver side.

PARTS LIST ... The part number is stamped into each part or printed on an adhesive label. Identify each part and place the appropriate mounting hardware with it.

PART NO.	DESCRIPTION	NEW ATTACHING HARDWARE (Qty.)
55-03-92075	bracket, steering stabilizer-to- tie rod	(1) 1/2" x 2-1/2" bolt (1) 1/2" Stover nut (1) 7/16" USS washer (4) 3/8" flange nut (2) 3/8" x 2-1/2" U-bol (1) 1/2" ID x 1-3/8" sleeve

- 55-02-92075 bracket, steering stabilizer-to- (1) 1/2" x 1" bolt
 axle (1) 1/2" Stover nut
 (1) 1/2" SAE washer
 (1) 1/2" mounting stud
 *(1) 1/2" nut
 *(1) 1/2" lockwasher
 *(1) 7/16" nut
 *(1) 7/16" lockwasher
 *(1) 7/16" USS washer

* Denotes that this hardware is bagged with 1/2" mounting stud.

- Part numbers depend on type orderedsteering stabilizer cylinder
 0046stabilizer decal, Superlift
 00421vehicle decal, Superlift

INSTALLATION PROCEDURE

1) **PREPARE VEHICLE...** Place vehicle on level ground. Put the transmission in Park or Low gear and set the parking brake. Be sure the tires are pointed straight ahead.

2) **REMOVE FACTORY STABILIZER...**
 Remove the factory steering stabilizer cylinder.
 Remove factory cylinder-to-tie rod bracket.

3) **STEERING STABILIZER AXLE BRACKET...**
 [DIAGRAM 1]
 Locate the small hole on the track bar mount above and to the outboard side of the track bar mounting hole. Drill out this hole using a 17/32" bit. Remove track bar bolt at the axle.

Position the axle bracket (#55-02-92075) on the front face of the factory track bar mount. Note there is a notch in the edge of the bracket that should face the passenger side of the vehicle.

Attach axle bracket using the supplied 9/16" x 3" bolt and Stover nut with a 9/16" SAE washer on both the bolt head and nut sides. Also insert the supplied 1/2" x 1" bolt, SAE washer and Stover nut; place the washer on the bolt head side.

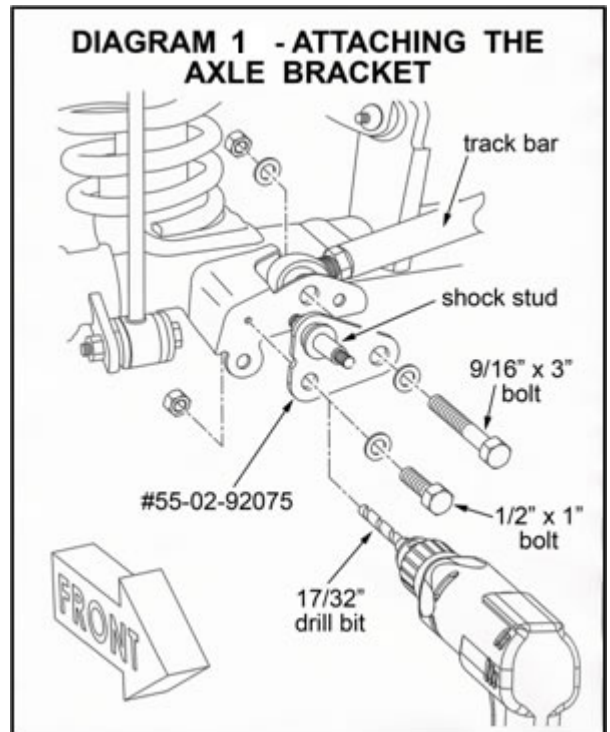

- Tighten both the axle and frame end of the track bar (125).
 Tighten the 1/2" bolt (57).

Install the supplied 1/2" mounting stud through the remaining hole in the axle bracket and secure using the supplied 1/2" nut and lockwasher. The stud should point forward. Tighten (57).

4) STEERING STABILIZER TIE ROD BRACKET... [DIAGRAM 2]

Verify the tires, not the steering wheel, are pointed straight ahead.

To ensure that the tie rod assembly is in proper position in relation to the knuckles, verify that the upper face of each tie rod end body is perfectly parallel with the bottom face of the knuckles (where the tie rod ends attach). If not parallel, rotate the tie rod assembly (by hand) as necessary.

The distance from center of the mounting stud to center of the tie rod bracket mounting hole is 15-1/2". Position the tie rod bracket (#55-03-92075) onto the tie rod accordingly. Also, the tie rod bracket should point "up", as shown, and from a side view be 90 degrees perpendicular to the tie rod. Attach the tie rod bracket using the supplied 3/8" x 2-1/2" U-bolts and flange nuts. Tighten the tie rod bracket U-bolt nuts (23). Note that the tie rod bracket's positioning may require fine tuning; a clearance check is performed in a later step.

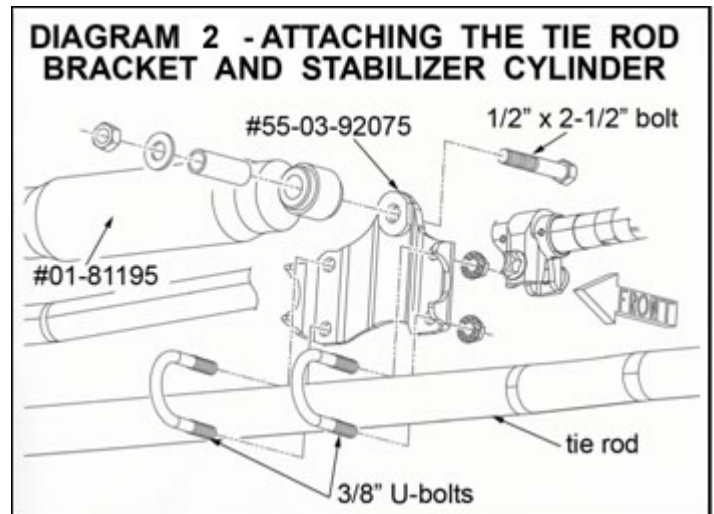

5) STABILIZER CYLINDER... [DIAGRAM 2]

Attach the body end of the stabilizer cylinder to the tie rod bracket using the supplied 1/2" x 2-1/2" bolt, 7/16" USS flat washer, and Stover nut, pointing forward, as shown. Tighten (75).

Attach the rod end of the stabilizer cylinder to the axle bracket stud using the supplied 7/16" USS washer, lockwasher and nut. Tighten until the bushings swell slightly.

Have an assistant cycle the steering lock to lock while you observe the steering stabilizer. Verify that the stabilizer operates smoothly and does not contact the steering linkage or other components. Also verify that the stabilizer does not "bottom" or "top" out, which will limit the steering before it contacts the steering stops. It may be necessary to adjust the position of the tie rod bracket until the necessary clearance / travel is achieved.

Install Superlift stabilizer cylinder decal.

6) CENTER THE STEERING WHEEL...

IMPORTANT: The steering wheel must be centered prior to driving the vehicle, or an Electronic Stability Program sensor may be activated resulting in a dash light and a warning chime that requires 20 plus ignition key cycles to clear.

Start engine and turn the steering wheel so that tires point straight ahead. Loosen the nuts on the drag link adjustment sleeve then rotate the sleeve until steering wheel center is achieved.

IMPORTANT: [DIAGRAM 3] In order to achieve proper adjustment sleeve clamping force, clamp / bolt assemblies (found on the drag link and tie rod assemblies) must be positioned as shown. The open side of each clamp must align with the slot in the threaded adjustment sleeve. Improper positioning and bolt torque will promote linkage deflection, which may contribute to tire shimmy. Tighten clamp bolts (26). Also relay this information to the alignment shop that performs the final alignment.

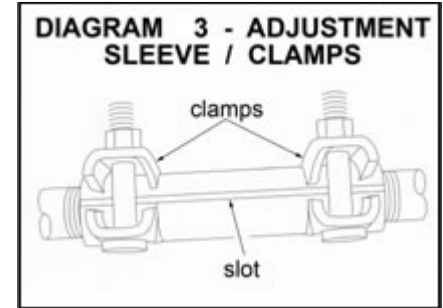

7) FINAL CLEARANCE and TORQUE CHECK...

Cycle steering lock-to-lock and inspect the tires / wheels, and the steering, suspension, and brake systems for proper operation, tightness, and adequate clearance.

Limited Lifetime Warranty / Warnings

Your Superlift® product is covered by the Limited Warranty explained below that gives you specific legal rights. This limited warranty is the only warranty Superlift® makes in connection with your product purchase. Superlift® neither assumes nor authorizes any retailer or other person or entity to assume for it any other obligation or liability in connection with this product or limited warranty.

What is covered? Subject to the terms below, Superlift® will repair or replace its products found defective in materials or workmanship for so long as the original purchaser owns the vehicle on which the product was originally installed. Your warrantor is LKI Enterprises, Inc. d/b/a Superlift® Suspension Systems ("Superlift®").

What is not covered? Your Superlift® Limited Warranty does not cover products, parts or vehicles Superlift® determines to have been damaged by or subjected to:

- Alteration, modification or failure to maintain.
- Normal wear and tear (bushings, tie-rod ends, etc.). Scratches or defects in product finishes (powdercoating, plating, etc.),
- Damage to or resulting from vehicle's electronic stability system, related components or other vehicle systems.
- Racing or other vehicle competitions or contests. Accidents, impact by rocks, trees, obstacles or other aspects of the environment.
- Theft, vandalism or other intentional damage.

Remedy Limited to Repair / Replacement. The exclusive remedy provided hereunder shall, upon Superlift's inspection and at Superlift's option, be either repair or replacement of product or parts covered under this Limited Warranty. Customers requesting warranty consideration should contact Superlift® by phone (1-800-551-4955) to obtain a Returned Goods Authorization number. All removal, shipping and installation costs are customer's responsibility.

If a replacement part is needed before the Superlift® part in question can be returned, you must first purchase the replacement part. Then, if the part in question is deemed warrantable, you will be credited / refunded.

Other Limitations - Exclusion of Damages - Your Rights Under State Law

- Neither Superlift® nor your independent Superlift® dealer are responsible for any time loss, rental costs, or for any incidental, consequential or other damages you may have.
- This Limited Warranty gives you specific rights. You may also have other rights that vary from state to state. For example, while all implied warranties are disclaimed herein, any implied warranty required by law is limited to the terms of our Limited Lifetime Warranty as described above. Some states do not allow limitations of how long an implied warranty lasts and / or do not allow the exclusion or limitation of incidental or consequential damages, so the limitations and exclusions herein may not apply to you.

Important Product Use and Safety Information / Warnings

As a general rule, the taller a vehicle is, the easier it will roll over. Offset, as much as possible, what is lost in rollover

resistance by increasing tire track width. In other words, go "wide" as you go "tall". Many sportsmen remove their mud tires after hunting season and install ones more appropriate for street driving; always use as wide a tire and wheel combination as feasible to enhance vehicle stability. We strongly recommend, because of rollover possibility, that the vehicle be equipped with a functional roll bar and cage system. Seat belts and shoulder harnesses should be worn at all times. Avoid situations where a side rollover may occur.

Generally, braking performance and capabilities are decreased when significantly larger / heavier tires and wheels are used. Take this into consideration while driving. Also, changing axle gear ratios or using tires that are taller or shorter than factory height will cause an erroneous speedometer reading. On vehicles equipped with an electronic speedometer, the speed signal impacts other important functions as well. Speedometer recalibration for both mechanical and electronic types is highly recommended.

Do not add, alter, or fabricate any factory or aftermarket parts to increase vehicle height over the intended height of the Superlift product purchased. Mixing component brands is not recommended.

SUPERLIFT SUSPENSION SYSTEMS

300 Huey Lenard Loop Rd.
West Monroe, Louisiana 71292
Phone: (318) 397-3000
Sales / Tech: 1-800-551-4955
FAX: (318) 397-3040
www.superlift.com